

Installation Instructions - Seip electric door operators

Procedure for fitting a Seip electric operator to a horizontally tracked one-piece up & over garage door
(the procedure for fitting to sectional type up & over doors is similar)

Tools you will require:

A 13mm spanner, 10mm & 13mm hex sockets & wrench, pair of side cutters or combination pliers, hammer, pencil, No.2 Pozidrive screwdriver, electric drill, 5mm HSS drill, 5.5mm masonry drill, a 'pump action oilcan' filled with car engine oil, step ladder.

Before Getting Started

1/ A minimum clearance of 35mm is required between the top of the door and the ceiling/beams for the C-rail track.

Note: if you have insufficient clearance for the track, the operator can be mounted on the ceiling to the rear of the garage and connected to the door with an extended door arm as shown on right (contact us for details)

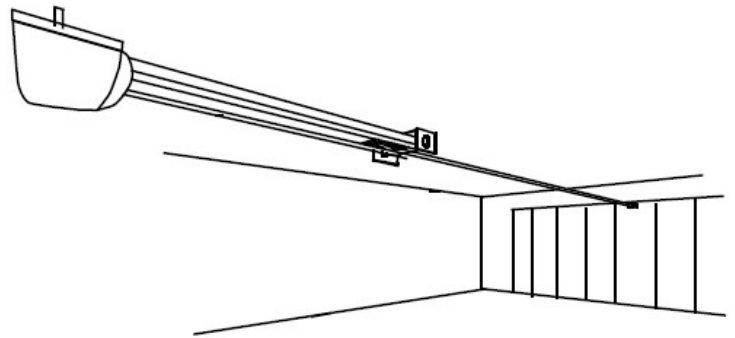

2/ If the door is higher than 2.4mtrs a C-rail track & chain extension kit may be required

3/ Lubricate all the pivot bearings & both roller spindles on the door support gear with oil and check the operation of the door with particular attention to correct spring balance, a correctly adjusted door should balance like a pair of weighing scales when the door is half open, if your door sinks heavily when stopped at this position the spring adjustments (on both sides) should be increased. The door should move freely through the opening without rubbing on the frame and should close snugly onto the frame at the bottom corners.

Contents of the installation hardware pack

One pair of motor support brackets, door header bracket & bolt, a selection of fixing screws, washers & masonry plugs, a small screwdriver, Allen key, bag containing eight track securing grub-screws & two emergency-release cable clamps, wireless wall mounted pushbutton switch & fixing screws. Units supplied by Amourelle Ltd also include 1Mtr of red P.V.C. sleeving for the emergency manual release cable and a label for the door with instructions detailing how to operate the door in the event of a power failure.



Unpacking and assembling the track

1/ Lay the operator on the floor with the motor head to the right hand side, slide part (1) out and fully engage it with the C-rail coupling piece (2)

2/ Slide section (3) out in front of part (1) keeping the chain free of twists

3/ Slide the C-rail coupling piece (4) out 25mm beyond the end of section (1) raise section (3) up at an angle as shown (below right) and press it down to stretch the chain and engage it with the C-rail coupling piece (4) and slide the C-rail coupling piece forward to cover the joint

4/ Turn the unit over and fit the M5 grub screws into the eight tapped holes and tighten with the Allen key provided
The chain is pre-tensioned and will not require any adjustment, your Seip operator is now ready for installation.

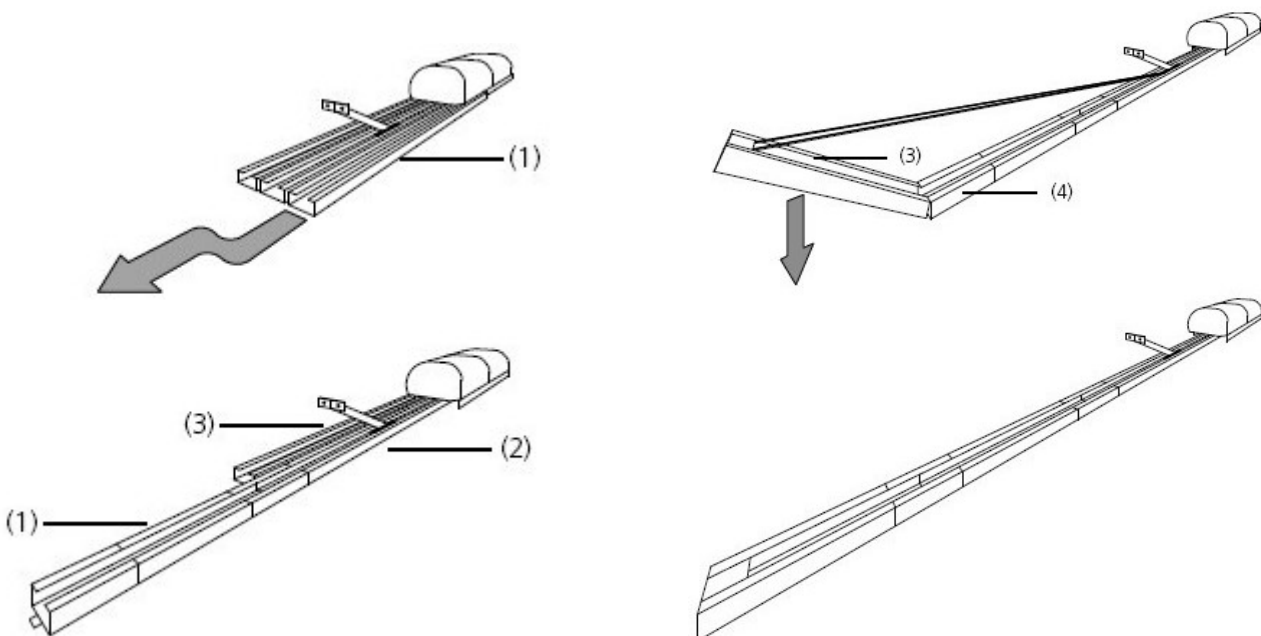

Mounting The Operator

- 1/ Close the door, measure the centre of the door and mark this position on the door and the frame header. Note: check that the door-frame header is securely fixed at the centre and make good with additional fixings if necessary.
- 2/ Fix the C-rail fixing bracket to the lintel, door header, or ceiling, as shown in Fig 1 or 2. *The ideal position is 50 - 100mm above the top edge of the door.*
- 3/ Place a carton on the floor to protect the motor casing and attach the C-rail to the front fixing bracket as shown in Fig 4
- 4/ Raise the motor head and support it either by using a strap from the beams or a pair of steps as in sketch as shown in Fig 5
- 5/ Open the door and align the C-rail track with the centre of the door and adjust the motor height to give a clearance of approx 30mm to 60mm between the C-rail track and the face of the door. The motor head may now be fixed to the ceiling with the brackets provided. (for model RP60A refer figs (4) and (4a) on page 7 of the manufacturers installation manual for fixing details) Note: If you have a high ceiling it may be necessary to extend the motor fixing brackets.
- 6/ Disengage the black sliding trolley from the chain drive (by pulling the manual release cable forward) and slide the trolley along the track towards the door. Note: With operator models TS75 and TS100 you may need to apply some force by hand to push the nylon blocks along the track in order to move the black sliding trolley to the desired position.
- 7/ Fix the door arm bracket to the top edge of the door as shown below. Four M6 self tapping screws & washers are provided for use on steel doors. For timber or G.R.P. doors use M8 x 40mm coach screws & washers.
- 8/ Disable the original manual latching system on the door, (the motor will automatically secure the door at the top when closed)
Note: Our Securi-Dor AP2000 multi-point locking system may be fitted to provide additional security by automatically engaging the door's original manual latches when closed.

Emergency Release Device

If your garage door is the only entrance you must provide a means of opening the garage door from outside in the event of power failure.

Seip operators feature a Bowden cable operated emergency door-release device to allow manual operation in case of power failure, this can be operated either from inside the garage, or from outside by means of the original locking door handle if you have a "vault type" garage (*no personal access door*)

Pic. 1

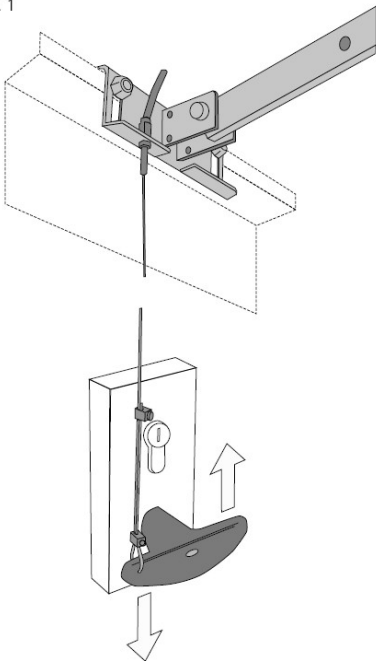

To enable the door to be released from outside with a key the emergency release cable should be connected to the original locking door handle as follows:
 Connect the emergency release cable to the back of the door's original handle so that when the handle is unlocked and turned from outside it pulls the cable downwards. *The sketch (Pic1) is only a guide as door handles vary according to the make of door.*

Note: Do not leave the garage and close the door until you have tested the operation of the emergency release from outside.

Get someone to test for correct operation of the handle & cable etc. while you are inside.

If your garage has a personal entrance door it is not necessary to connect the emergency release cable to the door handle as above

Note: we do not recommend using the red pull toggle supplied by the factory. We recommend that you fit 4mm red sleeving (supplied) over the cable instead and secure the end of the emergency release cable to a fixed point on the back of the door garage, this will enable manual operation from inside by pulling the cable.

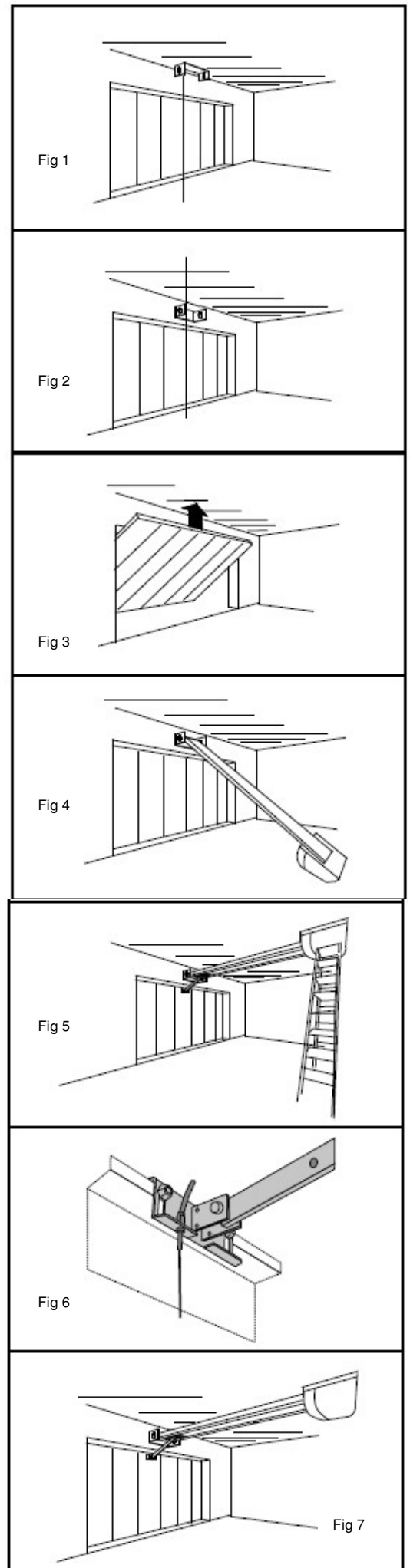

Mounting the wireless push button control switch

Pry out the switch assembly from the backplate and fix the backplate to the wall near the exit of your garage at a minimum height of 1.5 mtrs. using the two No 8 x 30mm screws & wall plugs provided.



Wireless wall control switch type WSW-1B

Mains Power Supply

1/ Your Seip door operator will require a 13A mains power point positioned on the ceiling approx. 3.4mts back from the centre of the door frame. *(alternatively a 13A extension lead can be run from an existing point)*

Limit-Switch Adjustment and Automatic Force Measurement

Please refer to the manufacturers installation manual enclosed with your specific operator model for this procedure

Important Note

Unless the above procedure has been completed the unit will only run for a few seconds before stopping

Final Check

After completing the adjustment procedure, open and close the door making sure that the motor stops at least 30mm before the door reaches the door support track end buffers when open, and stops without applying excessive pressure against the door frame when closed. *(test the operation of the manual release device because if too much force is applied against the door frame when the door is closed it will result in excessive force being require to operate the manual release device)*

Testing The Safety Stop Sensitivity

Stand outside and start the door in the CLOSE direction, when half closed, restrain the door by hand and check that the motor stops and reverses when hand pressure is applied to the lower edge of the door, a similar test should be carried out during the OPEN phase to make sure the door stops when hand pressure is applied to the lower edge of the door

Attach the yellow safety warning label (supplied) in a prominent position on the back of the door

The Installation is now complete ! - Relax & enjoy many years of effortless luxury & convenience !

Security

The motor will automatically lock the door at the top when closed. If physical security is an important issue Amourelle's unique Securi-Dor multi-point locking system can be fitted to enhance your security by automatically engaging additional side latches on the door when closed.

Optional infra-red break-beam safety detector kit

This device can be fitted to your Seip garage door operator for added safety

These instructions have been compiled by **Amourelle Ltd** and should be used in conjunction with the manufacturers installation instructions

If you require assistance ring 0118 969 4657 - Help is just a phone call away !
The UK's #1 Garage Door Automation Specialists

